

Online, In-Situ Calibration of Underwater Hydraulic Manipulators Using a Wrist-Mounted Camera

Amy Phung^{1,2}, Gideon Billings², Rich Camilli²

Olin College of Engineering¹, Woods Hole Oceanographic Institute²



Olin College
of Engineering

Motivation

- Hydraulic manipulators are used in underwater environments to collect samples that are critical for a variety of applications including: biological and geological sampling, seafloor pipeline inspection and repair, marine oil spill response
- Operating in deep-sea environments poses numerous technological challenges and constraints, such as communication bandwidth limitations, limited power for lighting and computation, and inability for human intervention
- Creating an automated system is key for overcoming these challenges
- Robust manipulator calibration is essential for safe and effective automation**

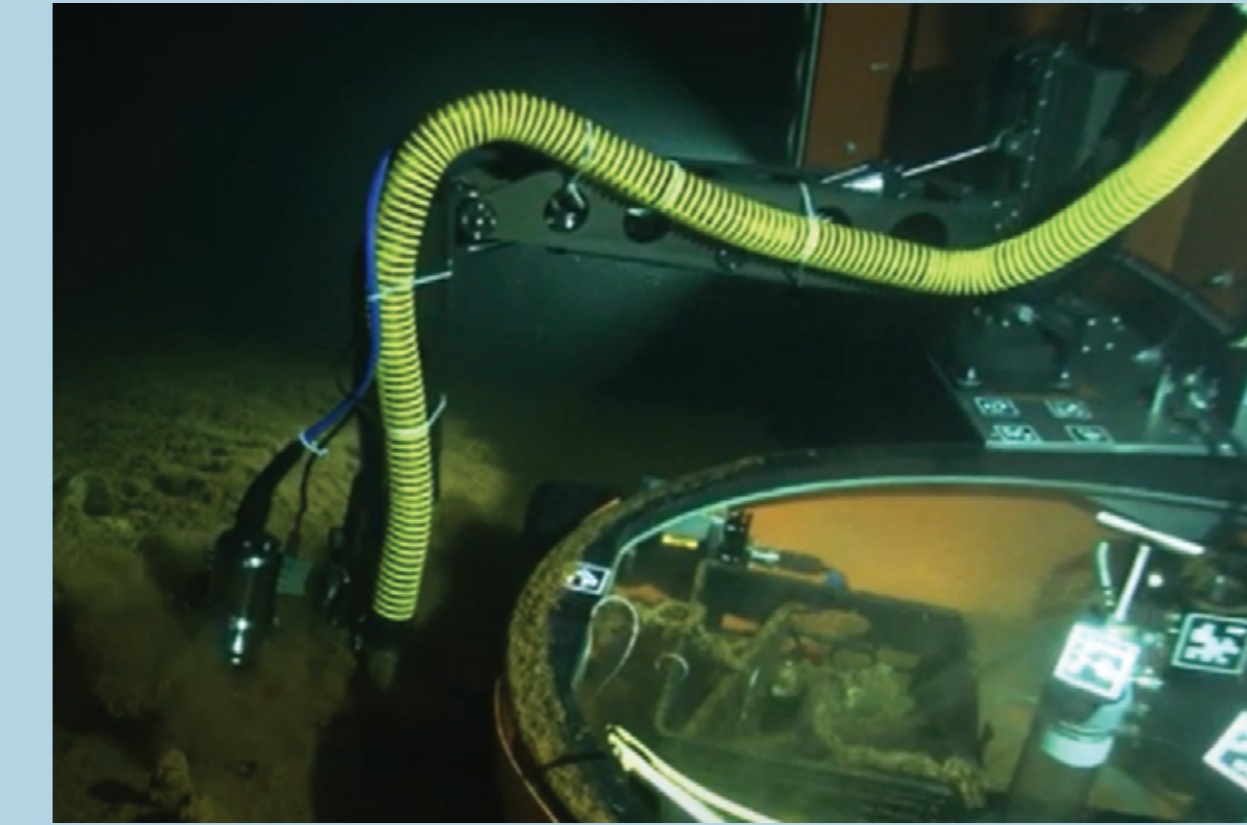

Fig 1: Biological sampling in the Kolumbo caldera

Background

The equation

$$\theta = \mathbf{k}_1 \eta + \mathbf{k}_2$$

θ : joint angle
 η : raw sensor output
 \mathbf{k}_1 : sensor gain
 \mathbf{k}_2 : sensor offset

represents the joint sensor to angle relationship

The objective of calibration is to find the optimal set of free parameters (gains \mathbf{k}_1 and offsets \mathbf{k}_2) for each of the 6 joints that minimizes the end-effector error.

The difficulty lies in simultaneously optimizing all 12 parameters, especially since small errors in each of these parameters compound. (e.g. 1 degree of error in the shoulder joint translates to over an inch of end-effector error for a 7-ft arm)

The redundancy of a 6 degree of freedom arm adds complexity to the calibration since end-effector position alone is not enough to know what the current joint angles are.

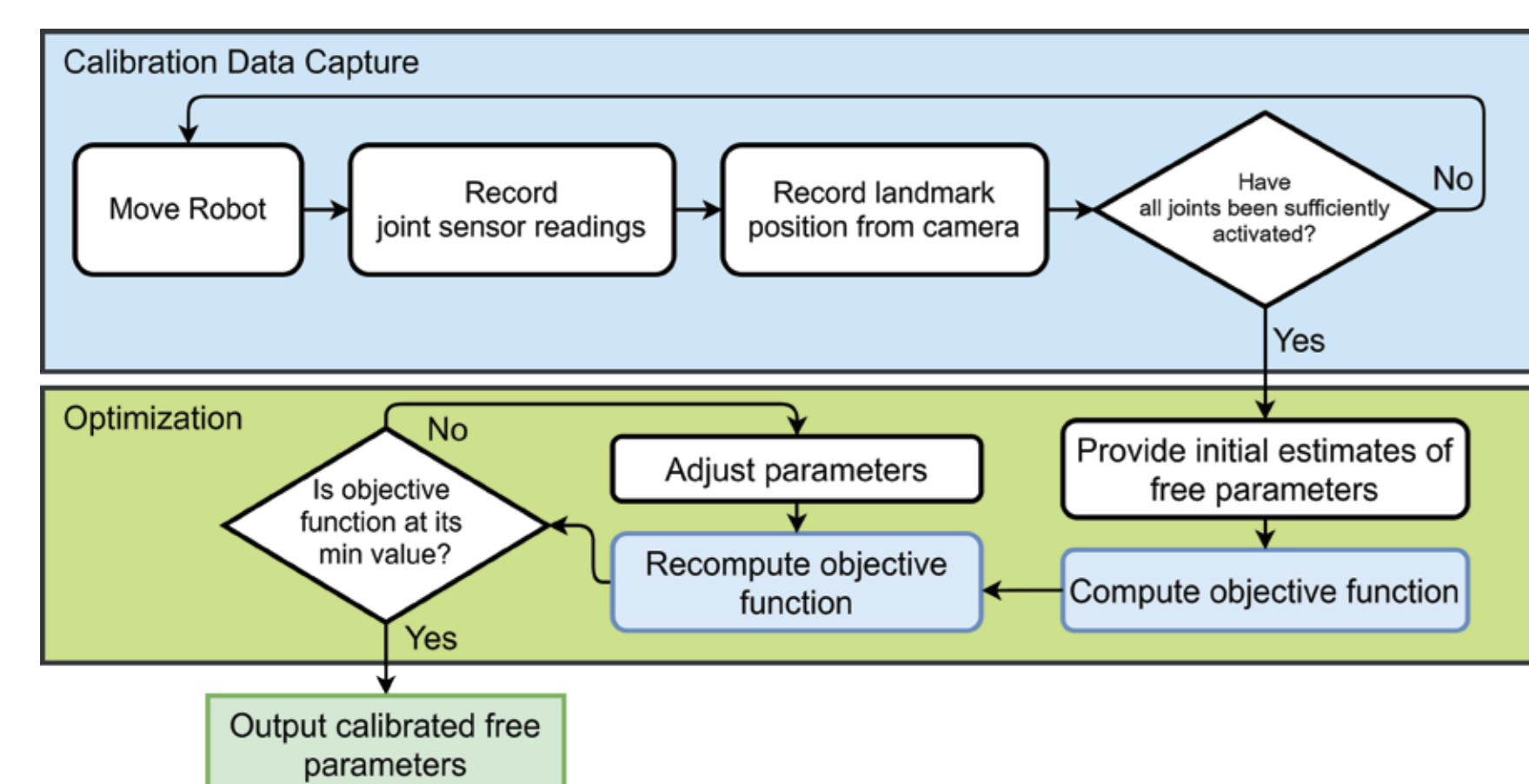

Fig 2: High-level overview of calibration process

Minimum Variance Method

The Minimum Variance method optimizes the free parameters by minimizing the variance of the fiducial tag observations

Requirements:

- Pre-calibrated camera
- Joint angle sensors
- Easily identifiable fiducial tags

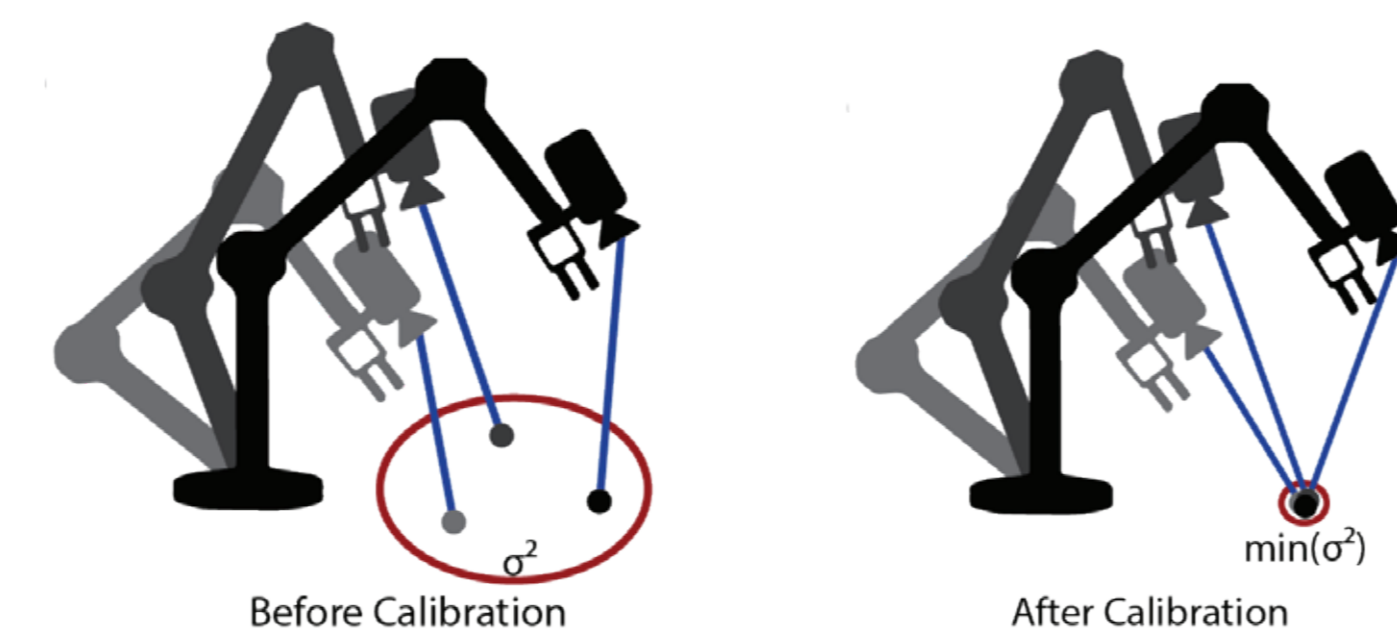

Fig 3: Minimum variance method visualization

Objective Function:

$$\mathbf{v}^* = \arg \min_{\mathbf{v}} \left(\sum_{j=1}^n (C_{j_{xx}} + C_{j_{yy}} + C_{j_{zz}}) \right)$$

Analysis:

- + Minimum number of requirements
- Extremely sensitive to measurement uncertainty
- No unique solution for shoulder joint

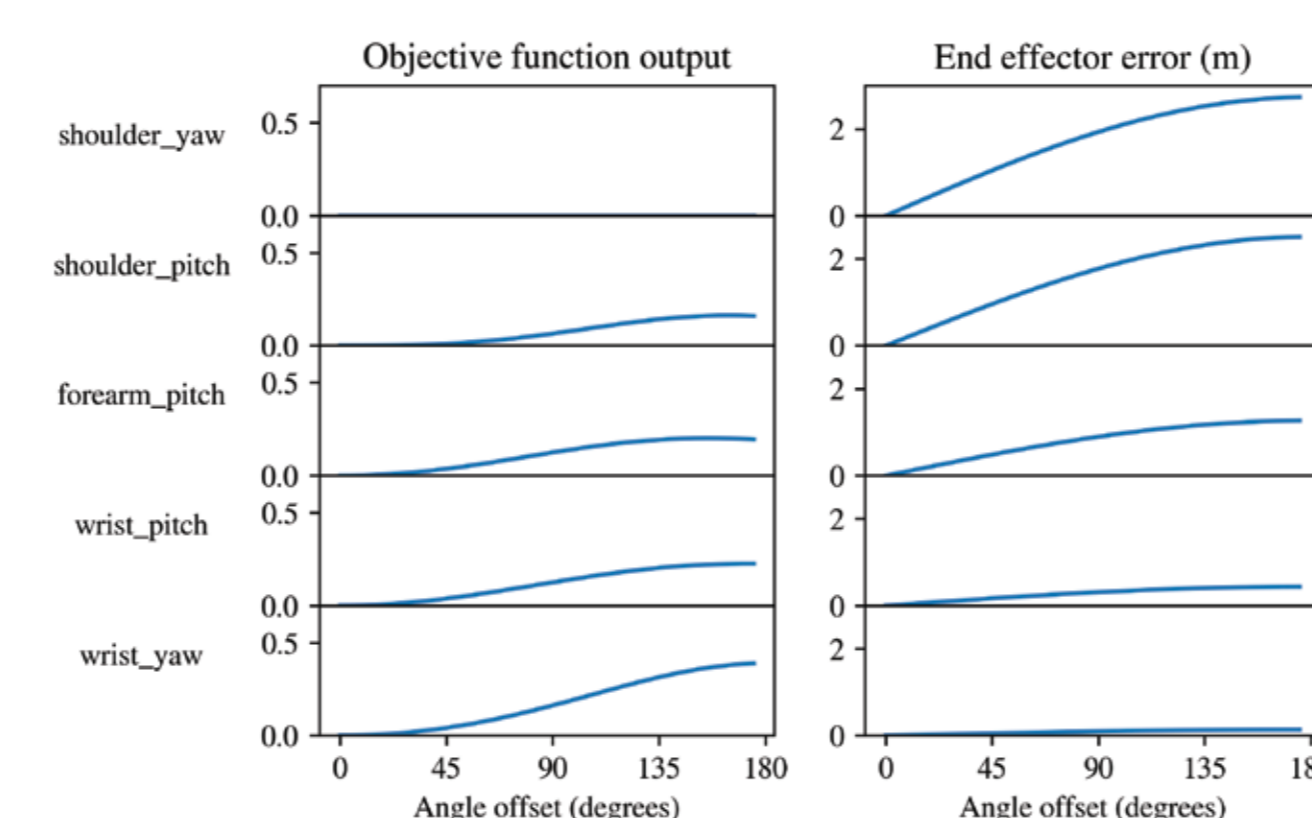

Fig 4: Minimum Variance method sensitivity test results

Minimum Distance Method

The Minimum Distance method optimizes the free parameters by minimizing the distance between fiducial tag projections and the known tag positions

Requirements:

- Pre-calibrated camera
- Joint angle sensors
- Easily identifiable fiducial tags
- Known location of at least one tag

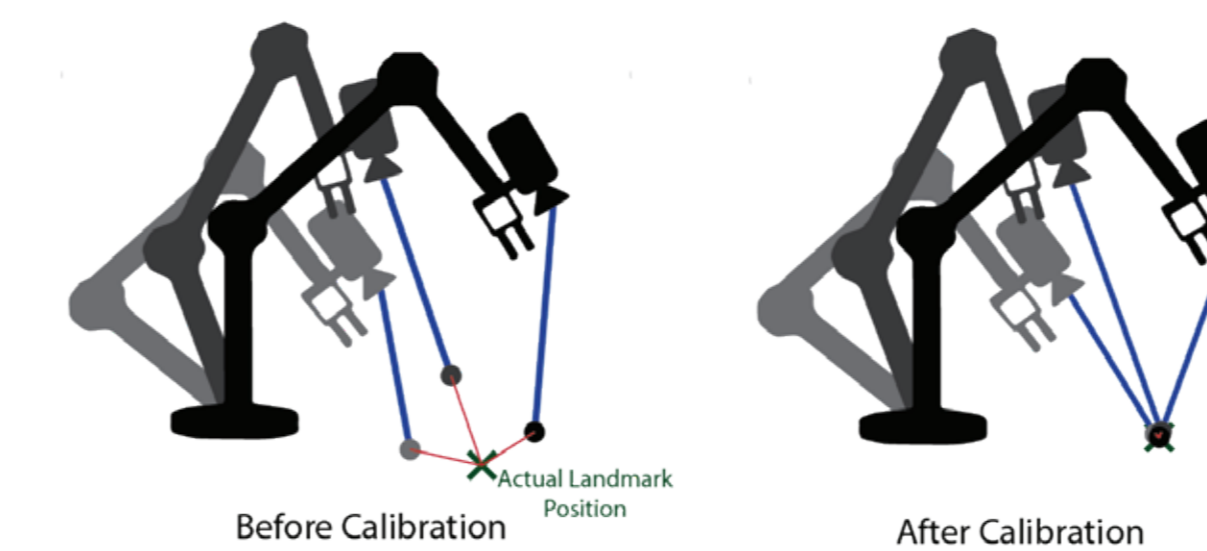

Fig 5: Minimum distance method visualization

Objective Function:

$$\mathbf{v}^* = \arg \min_{\mathbf{v}} \left(\sum_{j=1}^n \sum_{i=1}^m (d(\mathbf{z}_{ij}, \mathbf{z}_j)) \right)$$

Analysis:

- + Strong "gradient" to best solution
- + Robust to measurement uncertainty
- More requirements than the Minimum Variance method

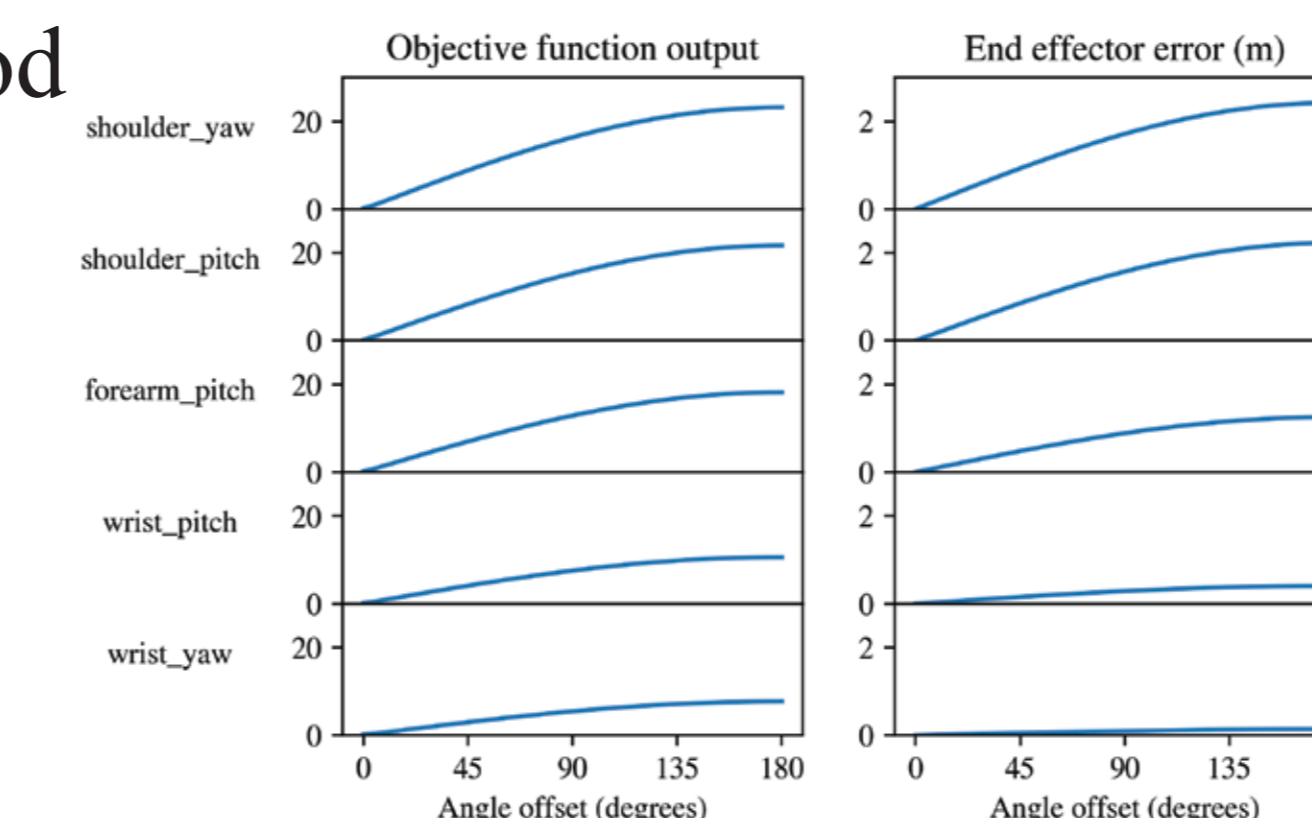

Fig 6: Minimum Distance method sensitivity test results

Implementation & Testing

Methods were implemented in Python & C++, and tested with prerecorded datasets in ROS. Results were visualized in RVIZ

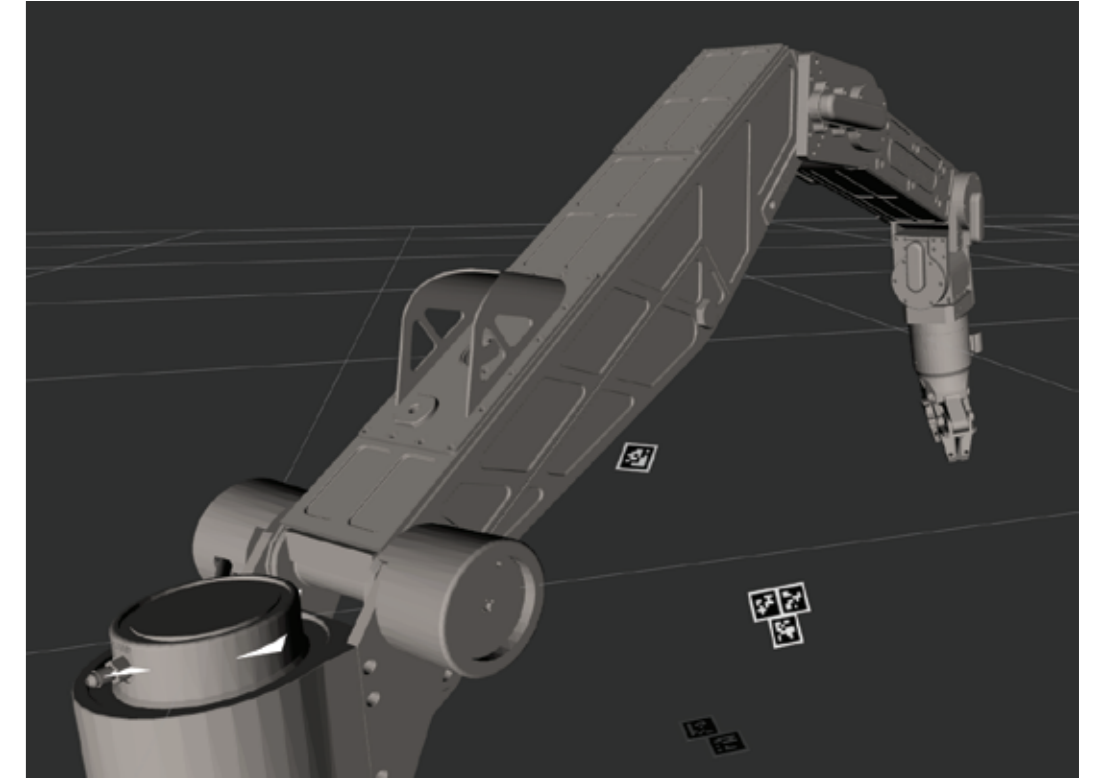

Fig 7: Manipulator model and fiducial tags in RVIZ

Conclusion

- While appealing since it has fewer requirements, the Minimum Variance method is not viable for calibration due to its extreme sensitivity to measurement uncertainty
- The Minimum Distance method is substantially more robust while only needing one more requirement than the Minimum Variance method
- The proposed calibration can be done in-situ, and is extensible to recalibration even with failed joints
- The robustness and independence from human intervention allows this calibration to potentially be used on extraterrestrial planetary landers

Next Steps

- Test implementation on testbed dataset
- Test implementation online with physical hardware
- Compare simulated results with test results

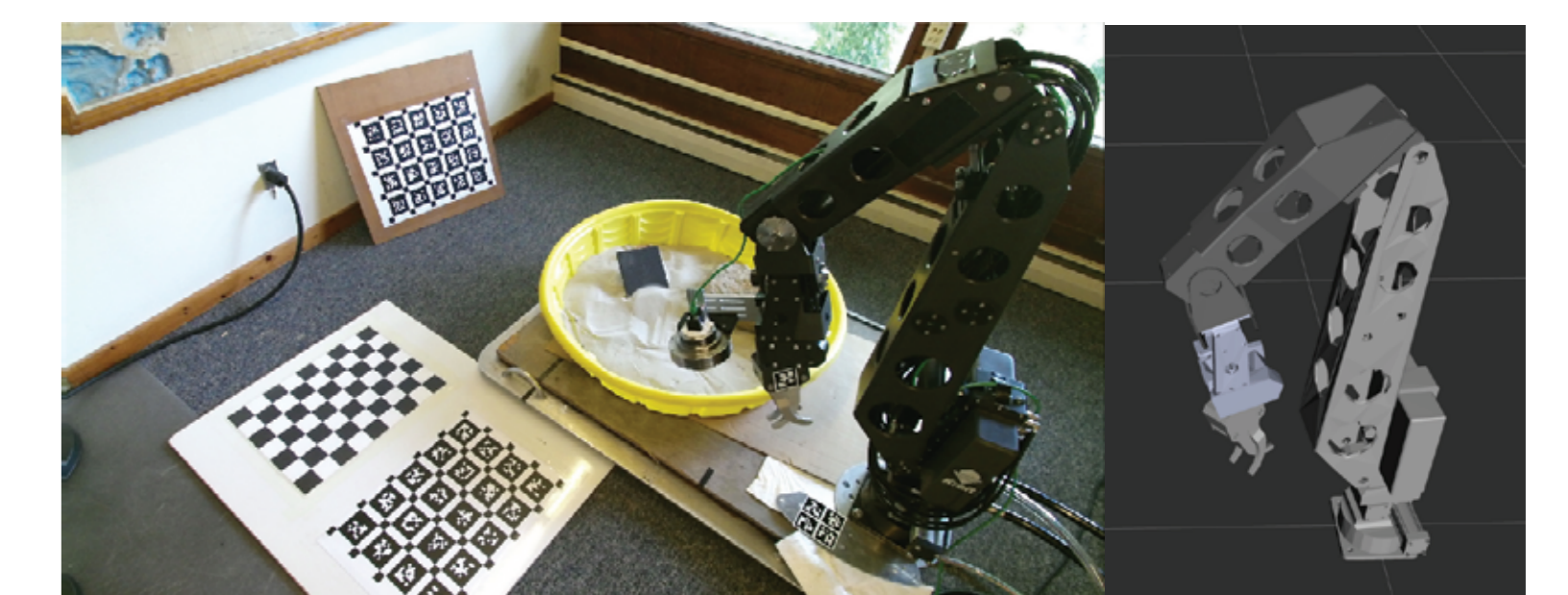

Fig 8: Physical and simulated testbed setup

Acknowledgements

I'd like to thank Kama Theiler and the WHOI Summer Student Fellowship program for making this project and summer experience possible.